

# SCAD TM1 and TM2 Tank Monitor Instruction Manual

## Introduction

The monitor can be used with SCAD's electronic external stick-on or internal rod sensors for water and holding tanks, and standard 240-33 Ohm or 10-180 Ohm float sensors. Additional related information is available at [www.scadtech.com/TMHelp](http://www.scadtech.com/TMHelp)

Included Parts	Required Tools and Materials
<ol style="list-style-type: none"><li>1. Monitor display</li><li>2. Wire harness</li><li>3. Inline 1 Amp fuse</li><li>4. Electronic external sensor module</li><li>5. 60 inches of aluminum sensor tape</li><li>6. 5 self tapping mounting screws</li></ol>	<ol style="list-style-type: none"><li>1. Drill with 1/2 inch (13mm) drill bit.</li><li>2. 22-18 AWG butt-splice terminations (preferably waterproof with heat shrink adhesive) and wire termination tools</li><li>3. 22 AWG stranded wire in 3 colors, preferably 3-conductor with red, blue or green, and black. Must span from the display to each sensor.</li><li>4. Isopropyl alcohol to clean any residue off the tank.</li><li>5. #1 Phillips screwdriver</li></ol>

## Installation

### Display Mounting

1. Choose a location for the monitor display that is away from weather or spilled fluids. Be sure there is sufficient access behind the panel to route the wires.
2. Hold the display with the face toward the mounting surface and mark the location of each of the four screw holes. Draw an X connecting the screw hole marks to determine the center. Measure down 5/16" from the center mark and Drill a 1/2 inch hole.

### External Sensor Foil Placement for Plastic & Fiberglass Tanks

Use the table and illustration below to determine the placement of the sensor components. Avoid areas near conductive objects. Clean all surfaces with isopropyl alcohol before component placement. Press firmly when adhering components.

### Component Placement Based on Foil Height (inches)

Foil Height	6-8	8-10	10-12	12-14	14-20	20-24	>24
Width	3-3.5	3	2	2	2	2	2
Gap	1-1.5	1.5-1.75	1.5	1.75	2	2.5	2.5-3

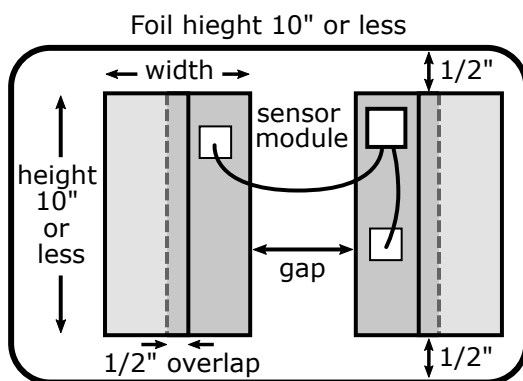
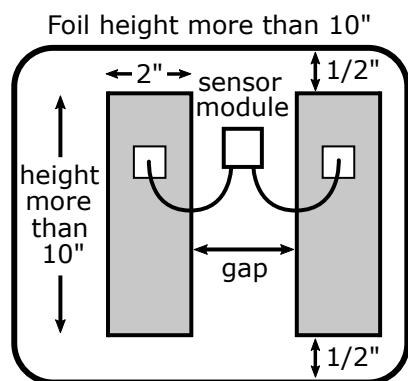

## System Wiring

- See figure below. BLACK wires are interchangeable. Power off when wiring. Make twist or wire nut connections initially and then butt-splice after successful setup. A color diagram of the wiring can be found at [www.scadtech.com/TMHHelp](http://www.scadtech.com/TMHHelp)

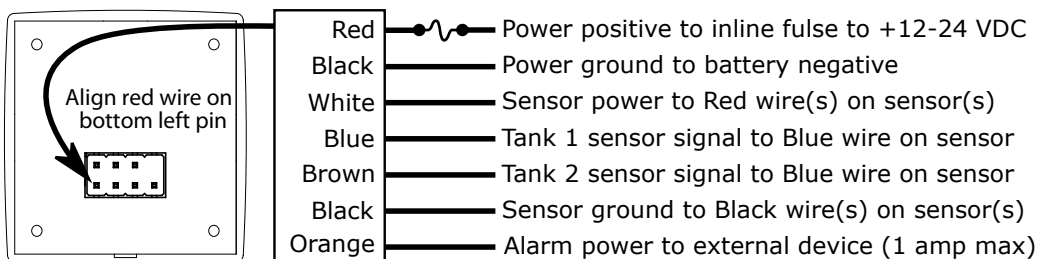

- Route 3-conductor #22 AWG wire (not supplied, see Required Tools and Materials) to each of the sensor modules. Pull the wire through the 1/2 inch hole you drilled in the Display Mounting instructions. Leave enough slack to strip and splice to the wire harness that plugs into the monitor display.
- Strip about 5/16 inches from the wires and connect the wires as described in Figure 1. We suggest using 22-18 waterproof heat shrink butt splice crimp connectors for your connections.
- Plug the wire harness into the monitor with the power off. Check for proper plug alignment. **WARNING: Plug misalignment can cause damage to the monitor!**
- Carefully screw the panel to the wall with the supplied #2 sheet metal screws. Hint: While not recommended, if using in a wet location, place a bead of silicone around the back edge of the monitor before screwing it to the wall to create a seal.

## Software Setup

### Overview

The software setup involves selecting options for parameters including sensor type, tank shape, and alarm function. Each parameter has several options, which are sequentially displayed as a flashing light (selectable option) or constant light (selected option) for 5 seconds before proceeding to the next option. Options are selected by tapping the touchpad. If you make a mistake, wait for the setup to complete and repeat the process. Setup also includes a tank calibration step that must be set for both empty and full when the tank is actually at those levels. Setup options are stored in memory even when power is removed. The following table is a reference for the Setup Instructions below:

ENTER SETUP: Touch pad until lights turn on from 1/8 through 7/8, then release.								
E	1/8	1/4	3/8	1/2	5/8	3/4	7/8	F
SENSOR TYPE				Diagnostic mode	10-180 Ohm	240-30 Ohm	Ext. < 8" Int. < 12"	Ext. > = 8" Int. > = 12"
	TANK SHAPE				Horizontal Cylinder	Severe taper	Mild taper	Rectangle
Alarm on empty		ALARM TYPE		No alarm		External alarm wire		Alarm on full
ENTER CALIBRATION: Touch pad while middle three lights are flashing.								
Empty				CALIBRATION				Full

## Setup Instructions

1. ENTER SETUP MODE: Press and hold touchpad 1 until lights illuminate from 1/8 through 7/8 after which the lights will turn off indicating the monitor is in setup mode. Remove your finger from the touchpad. Repeat the setup instructions for tank 2 on model TM2 using touchpad 2.
2. PARAMETER OPTION SELECTION: The setup mode sequentially advances to each option for each parameter every 5 seconds and advances to the next parameter. Tap the touchpad to select a desired option if its light is flashing. Parameters and options are presented as follows:
  - a. E light on = SENSOR TYPE parameter is active
    - i. F light = SCAD sensors: external 8" or longer, internal 12" or longer
    - ii. 7/8 light = SCAD sensors: external shorter than 8", internal shorter than 12"
    - iii. 3/4 light = 240–30 Ohm resistor type float sensor option
    - iv. 5/8 light = 10-180 Ohm resistor type float sensor option
    - v. 1/2 light = Diagnostic mode: raw sensor signal voltages. Ignore during setup. (more information at [www.scadtech.com/TMHelp](http://www.scadtech.com/TMHelp))
  - b. 1/8 light on = TANK SHAPE parameter is active
    - i. F light = Rectangular
    - ii. 7/8 light = Mild taper
    - iii. 3/4 light = Severe taper (almost triangular shape)
    - iv. 5/8 light = Horizontal cylinder
  - c. 1/4 light on = ALARM TYPE parameter is active
    - i. F light = Alarm on full
    - ii. E light = Alarm on empty
    - iii. 1/2 light = No alarm
    - iv. 3/4 light = External alarm wire energized on alarm condition. This is selectable if "Alarm on full" or "Alarm on empty" were previously selected. When the 3/4 light is flashing, the wire will not energize on alarm condition. Tap the touchpad to turn this option on. The 3/4 light will then be continuously on.
3. EXIT / RE-ENTER PARAMETER OPTION SELECTION: All lights will turn off, then on again for five seconds. If you want to re-enter the parameter option selection setup again, tap the touchpad. If you do not tap the touchpad, the monitor will proceed to calibration setup.
4. ENTER CALIBRATION SETUP: Next, the three top center lights will flash (3/8, 1/2 and 5/8) for five seconds. To enter the calibration setup, tap the touchpad while the lights are flashing. To skip the calibration setup, do nothing and the monitor will proceed to normal operation.
5. CALIBRATION: The 1/2 light will stay on to indicate the monitor is in calibration setup mode. Empty and full calibrations can be set at any time in any order. For example, if the monitor is in normal operating mode and you need to set an empty or full calibration, enter setup mode, wait for the parameters and options to sequence through, and then enter calibration mode as described above. Then calibrate as follows:
  - a. EMPTY Calibration – With an empty tank, while the E light is flashing, tap the touchpad to record the empty level. Do not tap the touchpad if you don't want to set the empty calibration.
  - b. FULL Calibration – With a full tank, while the F light is flashing, tap the touchpad to record the full level. Do not tap the touchpad if you don't want to set the full calibration.
6. EXIT CALIBRATION SETUP: All lights will turn off after full calibration and the monitor will return to normal operation.

## Operation

When power is applied to the monitor, each light will quickly turn on and off as it boots up, then the firmware version will be displayed (See Troubleshooting), after which it will be in normal operation. The monitor will automatically check for an alarm condition every few minutes. To see the level of a tank, tap the touchpad. If monitor detects and error, an error code will be displayed (see Troubleshooting). For continuous level display, tap the touchpad again within the 3 seconds. This feature is for monitoring the level while filling or pumping out a tank. The TM2 model will indicate the tank being monitored by illuminating the light next to the number 1 or 2. To exit continuous read mode, tap the touchpad.

## Alarm Function

If the tank was set to alarm on full, the F light will flash if the level is over 7/8. If the tank was set to alarm on empty, the E light will flash if the tank is below 1/8. On model TM2, lights 1 or 2 will indicate which tank is alarming.

## External Alarm

During an alarm condition, the orange external alarm wire is energized with the battery voltage level capable of current up to 1 amp, which can be used to power an indicator light, audible alarm or relay.

## Troubleshooting

Firmware version 3.1 and higher displays fault codes as blinking lights after touching the pad during normal operation. When the monitor is powered, all lights will cycle through, then turn off, followed by the firmware version, which is determined by counting lights to the left and right of the 1/2 light, which represents the decimal point. For example, three lights to the left of 1/2 and one light to the right is firmware version 3.1. More help is at [www.scadtech.com/TMHelp](http://www.scadtech.com/TMHelp)

Blinking Lights	<b>Symptom:</b> Possible causes. <u>Action</u>
<b>SENSOR FAULTS</b>	
1/2	<b>Sensor signal too low:</b> 1) No sensor connected. 2) No power to sensor. <u>Put monitor in continuous read mode and look for flashing lights at sensor. If not blinking, check wiring and connections.</u> 3) No signal returning from blue wire on sensor. <u>Check crimp connections from sensor blue wire.</u> 4) White wires not connected to external sensor foil strip. 5) Faulty float sensor.
1/2+5/8	<b>Sensor signal too high:</b> 1) Metal object bridging external sensor foil strips. 2) Black ground wire disconnected or blue signal shorted to white power wire. 3) Float sensor wiring open or faulty sensor. 4) Faulty monitor.
<b>CALIBRATION FAULTS</b> (Displayed after sensor faults.)	
1/8 (tank 1) 7/8 (tank 2)	<b>Empty calibration too low.</b> See sensor fault too low.
1/8+1/4 (tank 1) 7/8+3/4 (tank 2)	<b>Full calibration too high.</b> See sensor fault too high.
1/8+1/4+3/8 (tank 1) 5/8+3/4+7/8 (tank 2)	<b>Difference between empty and full too small.</b> 1) Full is calibrated before empty, which will be fixed once empty is calibrated. 2) Calibrated with no signal from sensor. See sensor fault signal too low. 3) Empty and full calibrated at the same signal level. 4) Short tank less than 7". <u>See foil placement section.</u> 5) Full and empty calibrations are reversed.
▲ SCAD Technologies • (336)793-2003 • <a href="http://www.scadtech.com/TMHelp">www.scadtech.com/TMHelp</a> • Firmware 3.2	